

Electrical characteristics

Type	CP223045
System	lithium/ manganese dioxide
Nominal capacity (mAh)	480@1mA to 2V @23°C
Rated voltage (V)	3.0
Impedence at 1kHz (Ω)	5
Max. continuous current (mA)	150
Max. pulse current (mA)	300
Storage temperature	-20 ~+40 °C
Operation temperature range	-20°C ~+60°C
Weight (g)	5.5
Specific energy	260Wh/Kg
Energy density	470Wh/L
Anode tape/cathode tape	Aluminum/Nickel
Self Discharge Rate	Under 2% for years@30°C
Jacket	Flexible Aluminum Foil Packaging
Max. dimensions (mm)	2.4×30.5×46

DATE SHEET-CP223045

3.0V 480mAh

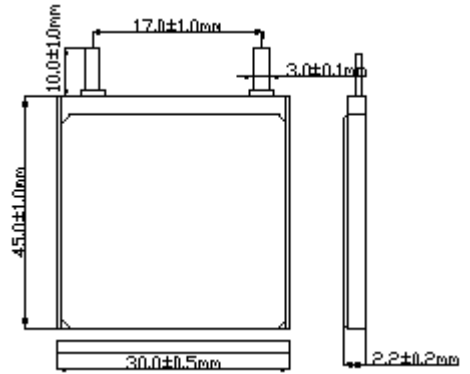

Key Features

- High Energy Density
- High single cell voltage
- Light weight
- Small Size
- High security
- Stable operating voltage
- Wide Operating temperature range
- Low Self-discharge rate
- Flexible on shape design
- Restricted for UL、UN38.3 and ROHS
- UL file: MH45782



Discharge Curve

DATE SHEET- CP223045

Constant Current

3.0V480mAh

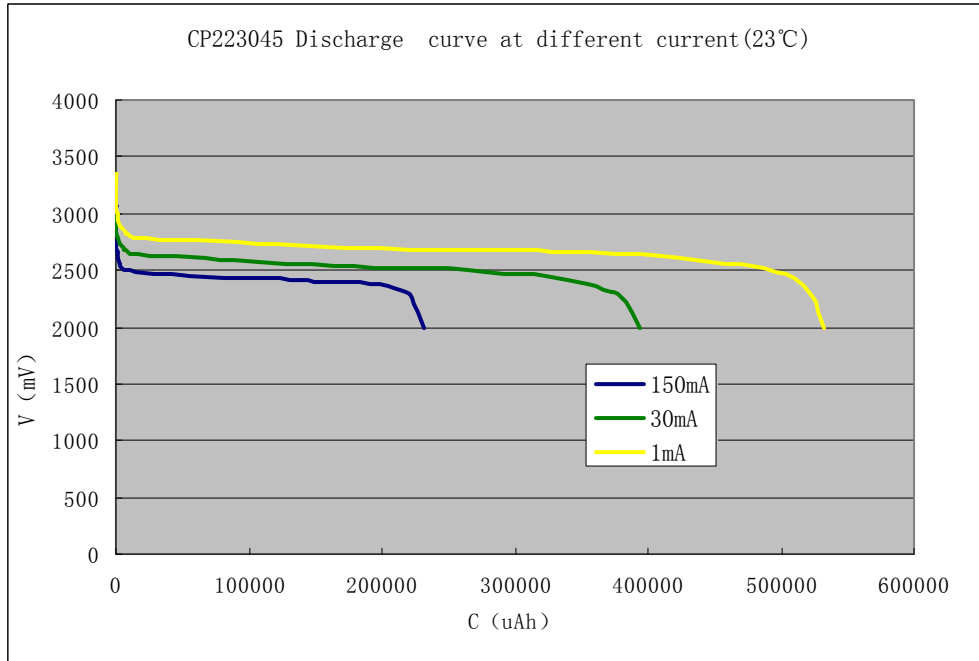

Capacity VS Temperature

